

- Single Device: 6A Output
- Input Voltage Range: 9V to 16V
- Adjustable Output Voltage
- 83% Efficiency
- Remote Sense Capability
- Standby Function
- Over-Temperature Protection

The PT6620 series is a line of 12V bus Integrated Switching Regulators (ISRs). These regulators are de-

signed for stand-alone operation in applications requiring as much as 6A of output current. The PT6620 series is packaged in Power Trends' standard 14-Pin SIP (Single In-line Package), which is available in either a vertical or horizontal configuration. Two electrolytic capacitors are required for proper operation.

Please note that this product does not include short circuit protection.

Standard Application

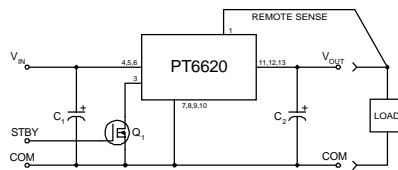

C₁ = Required 330µF electrolytic (1)
C₂ = Required 330µF electrolytic (1)
Q₁ = N-FET-or Open Collector Gate

Pin-Out Information

Pin	Function
1	Remote Sense
2	Do Not Connect
3	STBY*- Standby
4	V _{in}
5	V _{in}
6	V _{in}
7	GND
8	GND
9	GND
10	GND
11	V _{out}
12	V _{out}
13	V _{out}
14	V _{out} Adjust

Ordering Information

- PT6621□ = +3.3 Volts
- PT6622□ = +1.5 Volts
- PT6623□ = +2.5 Volts
- PT6624□ = +3.6 Volts
- PT6625□ = +5.0 Volts
- PT6626□ = +9.0 Volts
- PT6627□ = +1.8 Volts

PT Series Suffix (PT1234X)

Case/Pin Configuration	Heat Spreader	Heat Spreader with Side Tabs
Vertical Through-Hole	P	R
Horizontal Through-Hole	D	G
Horizontal Surface Mount	E	B

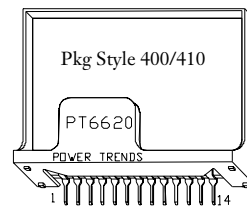

Note: Back surface of product is conducting metal

Specifications

Characteristics (T _a = 25°C unless noted)	Symbols	Conditions	PT6620 SERIES			Units	
			Min	Typ	Max		
Output Current	I _o	T _a = 60°C, 200 LFM, pkg P T _a = 25°C, natural convection	0.1 (2) 0.1 (2)	—	6.0 6.0	A	
Input Voltage Range	V _{in}	0.1A ≤ I _o ≤ 6.0A	+9 +6V ≤ V _o ≤ +9V	—	+16 +16	V	
Output Voltage Tolerance	ΔV _o	V _{in} = +12V, I _o = 6.0A T _a = 0 to 60°C	V _o -0.1	—	V _o +0.1	V	
Output Voltage Adjust Range	V _{oadj}	Pin 14 to V _o or ground	V _o = +3.3V V _o = +1.5V V _o = +2.5V V _o = +3.6V V _o = +5.0V V _o = +9.0V	2.3 1.4 1.9 2.5 2.9 5.2	— — — — — —	4.5 2.6 3.7 4.8 6.5 10.0	V
Line Regulation	Reg _{line}	V _{in} (min) ≤ V _{in} ≤ V _{in} (max), I _o = 6.0A	—	±0.5	±1.0	%V _o	
Load Regulation	Reg _{load}	V _{in} = +12V, 0.1 ≤ I _o ≤ 6.0A	—	±0.5	±1.0	%V _o	
V _o Ripple/Noise	V _n	V _{in} = +12V, I _o = 6.0A	—	50 1.0	— —	mVpp %V _o	
Transient Response with C ₂ = 330µF	t _{tr} V _{os}	I _o step between 3.0A and 6.0A V _o over/undershoot	—	100 150	— —	µSec mV	
Efficiency	η	V _{in} = +12V, I _o = 3.0A	V _o = +3.3/3.6V V _o = +1.5V V _o = +2.5V V _o = +5.0V V _o = +9.0V	— — — — —	84 68 76 86 93	— — — — —	%
		V _{in} = +12V, I _o = 6.0A	V _o = +3.3/3.6V V _o = +1.5V V _o = +2.5V V _o = +5.0V V _o = +9.0V	— — — — —	83 66 75 85 92	— — — — —	%
Switching Frequency	f _o	V _{in} (min) ≤ V _{in} ≤ V _{in} (max) 0.1A ≤ I _o ≤ 6.0	PT6622 Except PT6622	500 550	550 650	600 750	kHz kHz

Continued

PT6620 Series

6 Amp 12V Input
Integrated Switching Regulator

Specifications *(continued)*

Characteristics ($T_a = 25^\circ\text{C}$ unless noted)	Symbols	Conditions	PT6620 SERIES			Units
			Min	Typ	Max	
Absolute Maximum Operating Temperature Range	T_a	Over V_{in} range	-40	—	+85 ⁽³⁾	$^\circ\text{C}$
Storage Temperature	T_s	—	-40	—	+125	$^\circ\text{C}$
Mechanical Shock	—	Per Mil-STD-883D, Method 2002.3	—	500	—	G's
Mechanical Vibration	—	Per Mil-STD-883D, Method 2007.2, 20-2000 Hz, soldered in a PC board	—	7.5	—	G's
Weight	—	—	—	14	—	grams

- Notes:** (1) The PT6620 Series requires a 330 μF (output) and 100 μF (input) electrolytic capacitors for proper operation in all applications.
 (2) ISR will operate down to no load with reduced specifications
 (3) See safe Operating Area curves or contact the factory for the appropriate derating.

TYPICAL CHARACTERISTICS

PT6620 Series @ $V_{in}=+12\text{V}$ (See Note A)

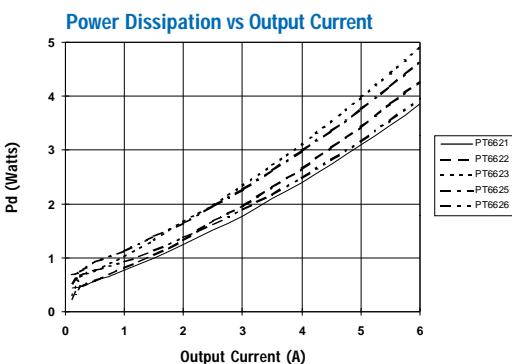
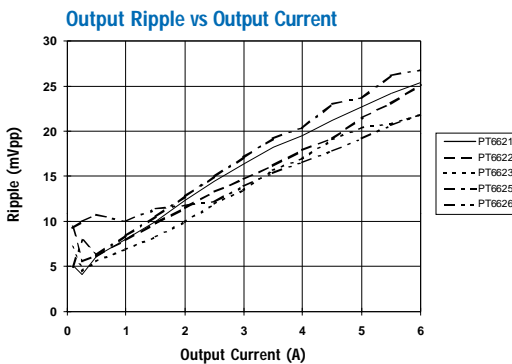
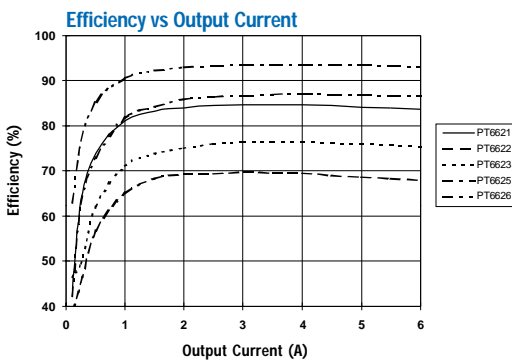

Safe Operating Area, $V_{in}=+12\text{V}$ (See Note B)

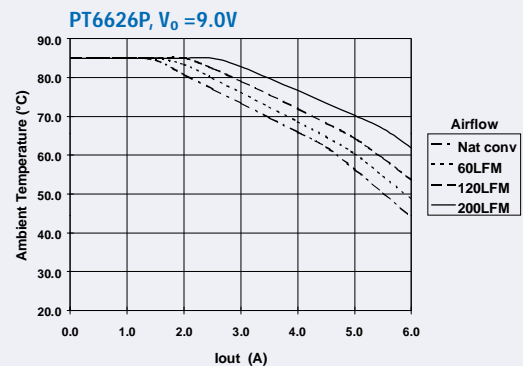
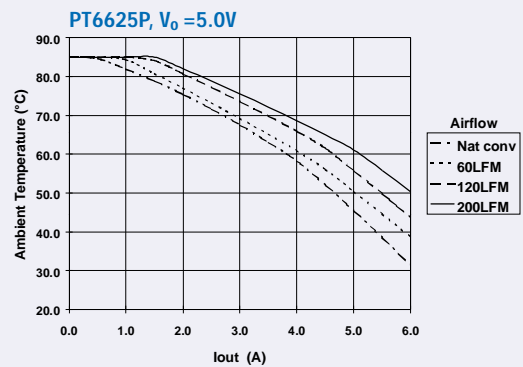
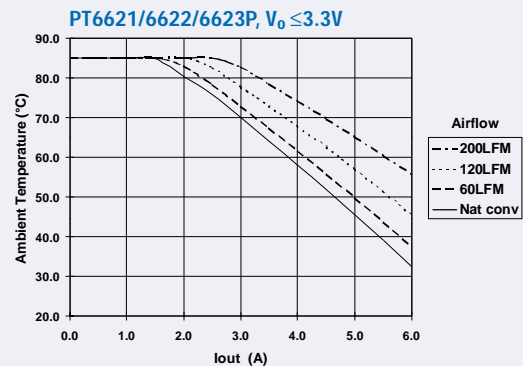

Note A: All characteristic data in the above graphs has been developed from actual products tested at 25°C . This data is considered typical for the ISR.

Note B: SOA curves represent operating conditions at which internal components are at or below manufacturer's maximum rated operating temperatures.

Adjusting the Output Voltage of the PT6620 7Amp12V Bus Converter Series

The output voltage of the Power Trends PT6620 Series ISRs may be adjusted higher or lower than the factory trimmed pre-set voltage with the addition of a single external resistor. Table 1 accordingly gives the allowable adjustment range for each model in the series as V_a (min) and V_a (max).

Adjust Up: An increase in the output voltage is obtained by adding a resistor R2, between pin 14 (V_o adjust) and pins 7-10 (GND).

Adjust Down: Add a resistor (R1), between pin 14 (V_o adjust) and pins 11-13 (V_{out}).

Refer to Figure 1 and Table 2 for both the placement and value of the required resistor, either (R1) or R2 as appropriate.

Notes:

1. Use only a single 1% resistor in either the (R1) or R2 location. Place the resistor as close to the ISR as possible.
2. Never connect capacitors from V_o adjust to either GND, V_{out} , or the Remote Sense pin. Any capacitance added to the V_o adjust pin will affect the stability of the ISR.
3. If the Remote Sense feature is being used, connecting the resistor (R1) between pin 14 (V_o adjust) and pin 1 (Remote Sense) can benefit load regulation.
4. The minimum input voltage required by the part is $V_{out} + 3$, or 9V, whichever is higher.

Figure 1

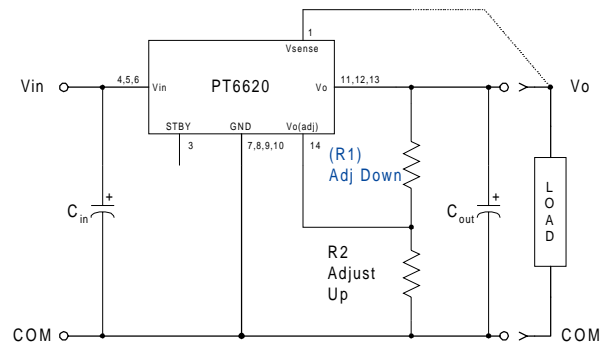

The values of (R1) [adjust down], and R2 [adjust up], can also be calculated using the following formulae.

$$(R1) = \frac{R_o (V_a - 1.25)}{(V_o - V_a)} - R_s \quad k\Omega$$

$$R2 = \frac{1.25 R_o}{V_a - V_o} - R_s \quad k\Omega$$

Where: V_o = Original output voltage
 V_a = Adjusted output voltage
 R_o = The resistance value in Table 1
 R_s = The series resistance from Table 1

Table 1

PT6620 ADJUSTMENT AND FORMULA PARAMETERS

Series Pt #	PT6622	PT6623	PT6621	PT6624	PT6625	PT6626
V_o (nom)	1.5V	2.5V	3.3V	3.6V	5.0V	9.0V
V_a (min)	1.4V	1.9V	2.3V	2.5V	2.9V	5.2V
V_a (max)	2.7V	3.7V	4.5V	4.8V	6.5V	10.0V
R_o (k Ω)	4.99	10.0	12.1	12.1	16.2	12.1
R_s (k Ω)	2.49	4.99	12.1	12.1	12.1	12.1

PT6620 Series

Table 2

PT6620 ADJUSTMENT RESISTOR VALUES

Series Pt #	PT6622	PT6623	PT6621	PT6624	PT6625	Series Pt #	PT6625	PT6626
Current	7.5A _{dc}	7.5A _{dc}	7.5A _{dc}	7.5A _{dc}	6.0A _{dc}	Current	6A _{dc}	3.3A _{dc}
V ₀ (nom)	1.5V _{dc}	2.5V _{dc}	3.3V _{dc}	3.6V _{dc}	5.0V _{dc}	V ₀ (nom)	5.0V _{dc}	9.0V _{dc}
V _a (req'd)						V _a (req'd)		
1.4	(5.0)kΩ					5.2	89.1k	(0.5)kΩ
1.5						5.3	55.4k	(1.1)kΩ
1.6	59.9k					5.4	38.5k	(1.9)kΩ
1.7	28.7k					5.5	28.4k	(2.6)kΩ
1.8	18.3k					5.6	21.7k	(3.4)kΩ
1.9	13.1k	(5.8)kΩ				5.7	16.8k	(4.2)kΩ
2.0	10.0k	(10.0)kΩ				5.8	13.2k	(5.1)kΩ
2.1	7.9k	(16.3)kΩ				5.9	10.4k	(6.1)kΩ
2.2	6.4k	(26.7)kΩ				6.0	8.2k	(7.1)kΩ
2.3	5.3k	(47.5)kΩ	(0.6)kΩ			6.1	6.3k	(8.1)kΩ
2.4	4.4k	(110.0)kΩ	(3.4)kΩ			6.2	4.8k	(9.3)kΩ
2.5	3.8k		(6.8)kΩ	(1.7)kΩ		6.3	3.5k	(10.5)kΩ
2.6	3.2k	120.0k	(11.2)kΩ	(4.2)kΩ		6.4	2.4k	(11.9)kΩ
2.7		57.5k	(17.1)kΩ	(7.4)kΩ		6.5	1.4k	(13.3)kΩ
2.8		36.7k	(25.4)kΩ	(11.3)Ω		6.6		(14.9)kΩ
2.9		26.3k	(37.8)kΩ	(16.4)kΩ	(0.6)kΩ	6.7		(16.6)kΩ
3.0		20.0k	(58.5)kΩ	(23.2)kΩ	(2.1)kΩ	6.8		(18.4)kΩ
3.1		15.8k	(99.8)kΩ	(32.7)kΩ	(3.7)Ω	6.9		(20.5)kΩ
3.2		12.9k	(224.0)kΩ	(46.9)kΩ	(5.5)kΩ	7.0		(22.7)kΩ
3.3		10.6k		(70.6)kΩ	(7.4)kΩ	7.1		(25.2)kΩ
3.4		8.9k	139.0k	(118.0)kΩ	(9.7)kΩ	7.2		(27.9)kΩ
3.5		7.5k	63.5k	(260.0)kΩ	(12.2)kΩ	7.3		(31.0)kΩ
3.6		6.4k	38.3k		(15.1)kΩ	7.4		(34.4)kΩ
3.7		5.4k	25.7k	139.0k	(18.4)kΩ	7.5		(38.3)kΩ
3.8			18.2k	63.5k	(22.3)kΩ	7.6		(42.8)kΩ
3.9			13.1k	38.3k	(26.9)kΩ	7.8		(53.9)kΩ
4.0			9.5k	25.7k	(32.5)kΩ	8.0		(69.6)kΩ
4.1			6.8k	18.2k	(39.2)kΩ	8.2		(93.0)kΩ
4.2			4.7k	13.1k	(47.6)kΩ	8.4		(132.0)kΩ
4.3			3.0k	9.5k	(58.5)kΩ	8.6		(210.0)kΩ
4.4			1.7k	6.8k	(73.0)kΩ	8.8		(445.0)kΩ
4.5			0.5k	4.7k	(93.2)kΩ	9.0		
4.6				3.0k	(124.0)kΩ	9.2		63.5k
4.7				1.7k	(174.0)kΩ	9.4		25.7k
4.8				0.5k	(275.0)kΩ	9.6		13.1k
4.9					(579.0)kΩ	9.8		6.8k
5.0						10.0		3.0k
5.1					190.0k			

R1 = (Blue) R2 = Black

Using the Standby Function on the PT6620 Series of 12V Bus Converters

For applications requiring output voltage On/Off control, the 14-pin PT6620 ISR series incorporates a standby function. This feature may be used for power-up/shut-down sequencing, and wherever there is a requirement for the output status of the module to be controlled by external circuitry.

The standby function is provided by the *STBY** control, pin 3. If pin 3 is left open-circuit the regulator operates normally, providing a regulated output whenever a valid supply voltage is applied to V_{in} (pins 4, 5, & 6) with respect to GND (pins 7-10). Connecting pin 3 to ground² will disable the regulator output and reduce the input current to less than 30mA⁴. Grounding the standby control will also hold-off the regulator output during the period that input power is applied.

The standby input is ideally controlled with an open-collector (or open-drain) discrete transistor (See Figure 1). It can also be driven directly from a dedicated TTL³ compatible gate. Table 1 provides details of the threshold requirements.

Table 1 Inhibit Control Thresholds (2,3)

Parameter	Min	Max
Enable (V_{IH})	1V	5V
Disable (V_{IL})	-0.1V	0.3V

Notes:

1. The Standby/Inhibit control logic is similar for all Power Trends' modules, but the flexibility and threshold tolerances will be different. For specific information on this function for other regulator models, consult the applicable application note.
2. The Standby input on the PT6620 regulator series may be controlled using either an open-collector (or open-drain) discrete transistor, or a device with a totem-pole output. A pull-up resistor is not necessary. The control input has an open-circuit voltage of about 1.5Vdc. To disable the regulator output, the control pin must be "pulled" to less than 0.3Vdc with a low-level 0.25mA max. sink to ground.
3. The Standby input on the PT6620 series is also compatible with TTL logic. A standard TTL logic gate will meet the 0.3V $V_{IL(max)}$ requirement (Table 1) at 0.25mA sink current. *Do not* drive the Standby control input above 5Vdc.
4. When the regulator output is disabled the current drawn from the input source is reduced to approximately 15mA (30mA maximum).
5. The turn-off time of Q_1 , or rise time of the standby input is not critical on the PT6620 series. Turning Q_1 off slowly, over periods up to 100ms, will not damage the regulator. However, a slow turn-off time will increase both the initial delay and rate-of-rise of the output voltage.

Figure 1

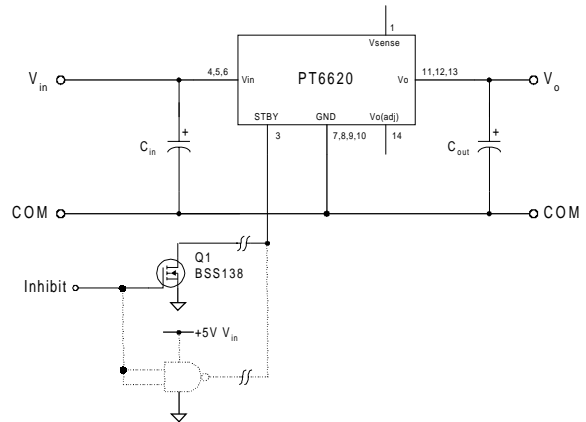

Turn-On Time: Turning Q_1 in Figure 1 off, removes the low-voltage signal at pin 3 and enables the output. The PT6620 series of regulators will provide a fully regulated output voltage within 20ms. The actual turn-on time may vary with load and the total amount of output capacitance. Figure 2 shows the typical output voltage waveform of a PT6625 (5.0V) following the prompt turn-off of Q_1 at time $t=0$ secs. The waveform was measured with a 12V input voltage, and 5A resistive load.

Figure 2

